

M ap li nèt ale

Liv Elèv Kreyòl

Tòm 3

Dezyèm
ane



USAID | **AYITI**
ÈD PÈP AMERIKEN

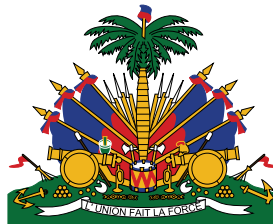

Ministère de l'Éducation Nationale
et de la Formation Professionnelle

M ap li nèt ale

Liv Elèv Kreyòl

Tòm 3

Dezyèm
ane



(Leson 96 -150)

Remèsiman espesyal

Metòd « M ap li nèt ale » se rezilta èd pèp ameriken an bay Ministè Edikasyon Nasyonal ak Fòmasyon Pwofesyonèl (MENFP) pa mwayen pwojè ToTAL (Tout Timoun Ap Li). Se RTI Entènasyonal k ap egzekite l pou USAID/ Ayiti.

Metòd « M ap li nèt ale, 2èm ane » a te jwenn konkou anpil moun pou l ka rive reyalize. Yo te pote kontribisyon yo nan konsepsyon ak elaborasyon materyèl la, nan fason yo te soutni travay la ak nan konsèy yo te bay. Se poutèt sa n ap remèsye espesyalman :

Moun ki te patisipe nan elaborasyon ak konsepsyon materyèl la :

- Marie-Jeanne Léo LOUIS-CHARLES, Spécialiste du développement des matériels de Créole, USAID/ RTI/ ToTAL
- Reginald Calixte BRICE, Educateur, Consultant, USAID/ RTI/ ToTAL
- Jovanny VINCENT, Educateur/ Consultant, USAID/ RTI/ ToTAL
- Standley KETAN, Educateur/ Consultant, USAID/ RTI/ ToTAL
- Stéphanie-Ingrid R. MOLEON, Educatrice/ Consultant, USAID/ RTI/ ToTAL
- Walph Ferentzi YOYOU, Educateur/ Consultant, USAID/ RTI/ ToTAL
- Marky JEAN-PIERRE, Consultant, RTI
- Emmanuel Michel BAZILE, Expert Linguiste, Ancien DG du MENFP, Consultant, USAID/ RTI (Editing)
- Pierre Michel LAGUERRE, Expert Linguiste, Ancien DG du MENFP, Consultant, USAID/ RTI (Editing)
- Jerry Rosembert MOISE et Mitchell Pierre, Illustrateurs, Consultants, USAID/ RTI/ ToTAL

Moun ki te soutni ak bay konsèy

- Loretta GARDEN, USAID
- Fabiola LOPEZ-MINATCHY, USAID
- Hervé JEAN-CHARLES, USAID
- Ronald JEAN-JACQUES, COP, RTI/ ToTAL
- Andrew JOHNSTON, DCOP, RTI/ ToTAL
- Mary DENAUW, Consultant, USAID/ RTI

- Laurette CUPIDON, Curriculum Development Manager, RTI/ ToTAL
- Josette GABOTON, Consultant, DEF/ EPT-BM
- Lionel HOGU, Consultant, DEF/ MENFP
- Françoise BENOÎT, DFP/ MENFP
- Zulda DUBOIS, DFP/ MENFP
- Volvick Germain CHARLES, Directeur, DEF/ MENFP
- Claudin SAINT- JOUR, Chef de service du Curriculum et formation, DEF, MENFP
- Jean Wilner Janvier (DEF/ MENFP)
- Chantal Roques (Consultante au MENFP)
- Claude Hebert Antoine (FONHEP)
- Jean Julien Ladouceur (CEEC)
- Jocelyne Trouillot (Université Caraïbe)
- Darline Alexis (Université Quisqueya)
- Charles Tardieu (Editions Zemès)

Moun ak lekòl ki te ede nan pilotaj pwogram nan

- Jean-Baptiste Michel BEL
- Filocie JEAN
- Roseline DORMÉUS
- Ezechias VILUS
- Damas AUGUSTIN
- Emmanuel FILIPPI
- Dieudonne JOSEPH
- Jean Daniel CLEDOR
- Alius JOSEPH

Ecole	Departement	Commune	Nom du directeur
Ecole Lumière Divine	Nord	Quartier Morin	Pierre Arnol
Ecole Nationale de Quartier Morin	Nord	Quartier Morin	Augustin Suza
Ecole Nationale Serge Luckecsy	Nord		Carole Antoine
Ecole Nationale Galman du Plat	Nord	Quartier Morin	Bernadette Magloire
Ecole Nationale Marcelin Prophète G. du Plat	Nord	Quartier Morin	Jasmine Magloire
Institut Scheche	Nord	Limonade	Modelaire Elminor
Ecole Maria Montessori	Nord	Limonade	Gesner Dieudonne
Ecole Eben-Ezer de Limonade	Nord	Limonade	P. Jecton Cerant
E.N.A.L.M Sabanon	Nord	Limonde	Jany Charles
Collège Evangélique Nouvelle Espérance	Nord	Limonde	René Julcoeur
Oeuvre humanitaire de Bois de Lance	Nord	Limonade	Décès Bien-Aimé
Ecole Nationale Eudes Jn Baptiste	Nord	Limonade	Jean Marie Charles
Ecole Nationale Claudius Codada	Nord	Limonade	Obéi Tony
Ecole Nationale de Cahess	Nord-Est	Caracol	Morisseau Augustin
S.E.H	Nord-Est	Caracol	Jean Mirvil
Rayaume des Petits	Nord_Est	Trou du Nord	Marseille Vernet
Ecole Nationale Jn Price Mars	Nord-Est	Trou du Nord	Eline Saint-Cléris
Ecole Nationale de Garcin	Nord-Est	Trou du Nord	Pierre Harry Jean Baptiste
Ecole Nationale de Devarenes	Nord-Est	Trou du Nord	Ida Fénéus
Collège Eben-Ezer de Trou-du-Nord	Nord-Est	Trou du Nord	Fellippe Elie
Nationale de Pister	Nord	Limonade	Moise Lesly

Sa ki nan liv la

Leson 96	2	Leson 124	47
Leson 97	3	Leson 125	49
Leson 98	5	Leson 126	50
Leson 99	6	Leson 127	52
Leson 100	8	Leson 128	53
Leson 101	9	Leson 129	55
Leson 102	11	Leson 130	56
Leson 103	12	Leson 131	58
Leson 104	14	Leson 132	59
Leson 105	15	Leson 133	61
Leson 106	18	Leson 134	62
Leson 107	19	Leson 135	64
Leson 108	21	Leson 136	65
Leson 109	22	Leson 137	67
Leson 110	24	Leson 138	68
Leson 111	25	Leson 139	70
Leson 112	27	Leson 140	71
Leson 113	28	Leson 141 Revizyon	73
Leson 114	30	Leson 142 Revizyon	74
Leson 115	31	Leson 143 Revizyon	75
Leson 116 Revizyon	34	Leson 144 Revizyon	77
Leson 117 Revizyon	35	Leson 145 Revizyon	78
Leson 118 Revizyon	37	Leson 146 Revizyon	80
Leson 119	39	Leson 147 Revizyon	81
Leson 120	41	Leson 148 Revizyon	83
Leson 121	43	Leson 149	84
Leson 122	44	Leson 150	86
Leson 123	46		

Leson 96

M ap mete lajwa nan katye mwen.



wonn



gwoup



Katye lakay mwen bèl !

Mwen kenbe li pwòp.

Mwen pa jete fatra toupatou.

Nou dekore l lè gen fèt.

Chak swa, se bèl anbyans :

Nou rakonte istwa, nou tire kont.

Katye lakay mwen se pa m !



frèt etidye reyini nèt fòme

gen kont wonn anbyans rakonte



Li fè frèt maten an.

Gen bèl anbyans nan fèt la.

Leson 97

Nou tout ka mete men pou nou fè katye nou vin pi bèl.

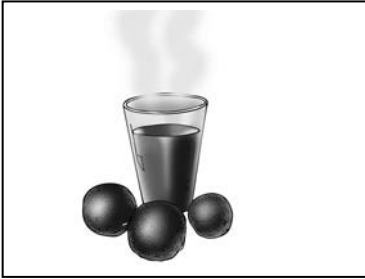

chokola

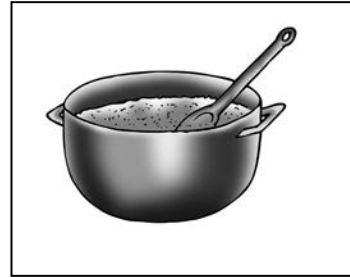

chodyè



Katye pa m se pou ou.

Katye pa w se pou mwen.

Nou tout responsab.

N ap mete men nan tout aktivite

Pou katye nou rete bèl.



kafe itil vann manje kwit zòn

swa chokola pen tounen



Kalin genyen yon jaden kafe.

Ednè pote pen pou timoun yo.

Konn Viv



Nan katye Zoranje, tout moun renmen vin bwè kafe kay Grann Mata. Kafe a bon. Epitou kafe grann Mata a pa koute chè. Yon jou, grann Mata di kliyan li yo : « Nou chak ka fè yon komès pou itil zòn nan. » Se konsa, lè maten, grann Mata toujou fè kafe. Nan apre midi, Linou vann manje kuit. Lè swa, Wolan fè chokola ak pen. 24 Desanm pral rive. Tout machann nan katye a te fè yon kolezepòl pou yo òganize yon bèl fèt.

Kesyon

1. Ki bò moun yo renmen bwè kafe ?
2. Ki sa Linou fè nan apre midi ?
3. Ki sa Wolan fè lè swa ?
4. Ki sa komèsan yo te deside fè pou 24 desanm ?

Leson 98

Lè mwen bay ak tout kè m, mwen ka resevwa sa mwen pa t espere.



gato

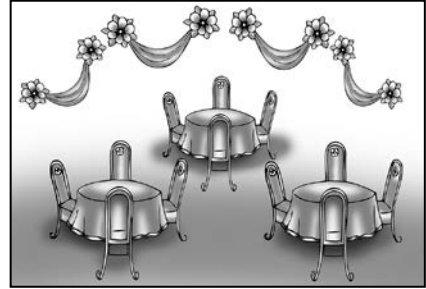

dekorasyon



Pataje se yon jès renmen.

M ap bay menm si li piti.

M ap bay ak tout kè m.

An nou pataje youn ak lòt.



fèt anivèsè zanmi pwa vyann

kwit gato lakou envite gwo



Fito manje yon bèl tranch gato.

Fèt Ivwoz la te gen anpil moun.

Leson 99

M ap byen prepare tout sa m ap fè.



nwèl



kado



Nwèl la rive byen banda
Tout bagay pare pou reveyon
Bèl mizik ak bon son
Bèl limyè ak dekorasyon
Bon manje ak bwason
Oulala ! Fèt la fèt nan lapè ak nan lajwa.



epòk nwèl komite prezidan
reyalize jou kòb bèl twazyèmman
lavèy



Makso bezwen kòb pou li achte yon kado.
Lavèy, Polin ale kay tant Jàn.

Nwèl rive



Epòk Nwèl te rive. Tout timoun sou katye a te decide fè yon fèt. Premyèman, yo mete ti kòb yo ansanm. Dezyèmman, yo fè yon komite pou òganize fèt la. Se Jil ki te prezidan komite a. Twazyèmman, komite a achte tout bagay lavèy jou fèt la. Finalman, komite a reyalize yon bèl fèt.

Kesyon

1. De ki sa istwa a pale ?
2. Ki sa timoun yo te decide fè ?
3. Kilès ki te prezidan komite a ?
4. Dapre nou, ki sa timoun yo te achte lavèy fèt la ?

Leson 100

Respè youn pou lòt pa gate zanmi.

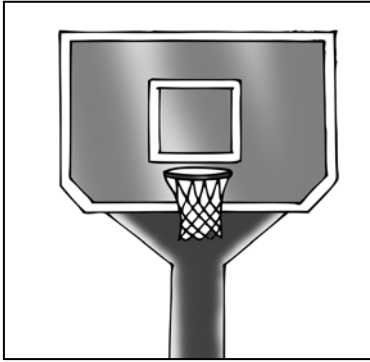

panye

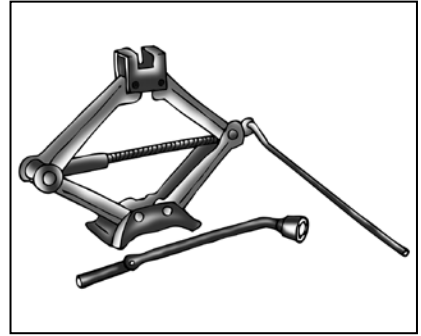

djak



Yon zanmi se yon frè oswa yon sè

Zanmi ede zanmi

Zanmi pwoteje zanmi

Lamitye se bèl bagay.



retire kivèt ranje lekòl prete

abiye responsab suiv liv konsiy



Jino ranje kabann li chak maten.

Anòt pa janm dechire liv li yo.

Leson 101

Mwen dwe panse ak lòt yo.

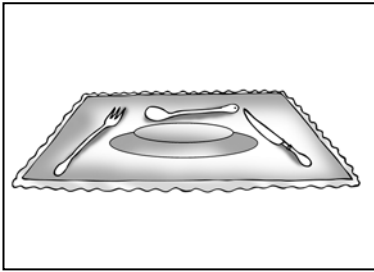

kouvè

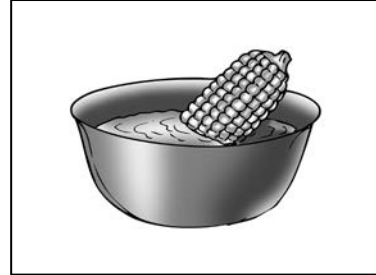

mayi bouyi



Tout pa dwe pou mwen.

Mwen dwe kite pou lòt yo.

Tout moun dwe jwenn.

Renmen tout se egoyis.

Lè kè mwen kontan,

Se lè tout moun jwenn.



bouyi ansanm paran labouyi

poko farin bon rès mayi vann



Fanò konn fè labouyi.

Elena kouvri rès manje a anba kouvrepla a.

Panse ak lòt yo



Yon maten, Lina mete mayi bouyi. Mmhh ! Mayi a santi bon! Li kite yon bèl bòl pou paran li. Epi li manje rès la ansanm ak ti frè li a. Nan apre midi, paran li sot travay. Lina al chèche rès mayi a. Woy ! men ti frè li a manje l. Lina gade li epi li di l :

- Ou dwe toujou kite manje pou moun ki poko manje yo.

Nan aswè, Lina fè labouyi farin mayi pou paran li.

Kesyon

1. De kilès istwa a pale ?
2. Kilè Lina te mete mayi a bouyi a ?
3. Ki sa ti frè Lina a te fè ?
4. Ki konsèy Lina te ba ti frè li a ?

Leson 102

Souri m montre mwen gen bon jan.

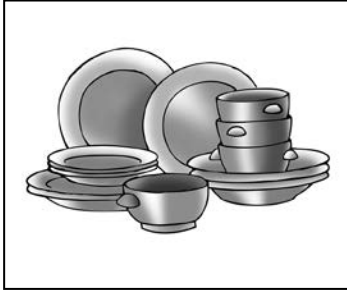

vesèl

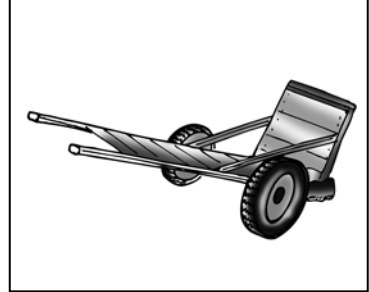

bourèt



Mwen souri toutan,
Paske mwen gen bon jan.
Mwen souri pou timoun.
Mwen souri pou granmoun.
Yon ti souri se yon jès lanmou.



machann lòt souri kliyan pri
sanble machandiz swa wout
kouri



Ivta toujou ap souri.
Wout la chaje ak pye palmis bò kote li.

Leson 103

N ap manje tout sa ki fèt ak mayi.



pilon

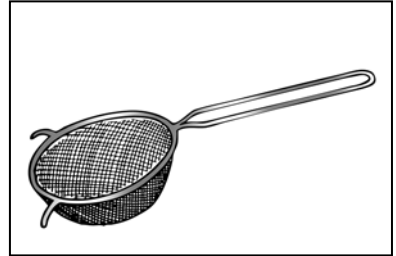

paswa



Timoun, timoun, pwoche, pwoche !

Nou pral fè chanmchanm.

Pòl, Ana ap grennen mayi.

Sizèt, Jonas, ap griye mayi.

Mariz, Pyero ap pile mayi.

N ap mete sèl ak sik.

Men chanmchanm, men chanmchanm.

N ap manje ak kè kontan.



vann prepare griye jòn fen

pase paswa mezire pilon

chanmchanm



Manman Lili ap vann twal nan mache Valyè.

Renòl al lave manch pilon an.

Yon bon chanmchanm



Madan Jan vann chanmchanm nan lekòl la. Yon jou, Djimi wè li k ap prepare chanmchanm. Premyèman, Madan Jan griye mayi a. Dezyèmman, li mete mayi a nan pilon. Li pile li byen fen. Twazyèmman, li pase li nan paswa. Chanmchanm nan santi bon ! Finalman, li mezire epi mete chanmchanm nan nan ti papye jòn. Chanmchanm Madan Jan se bon bagay.

Kesyon

1. De kilès istwa a pale ?
2. Ki sa Madan Jan vann ?
3. Ki sa li fè an premye lè l ap prepare chanmchanm ?
4. Ki lòt bagay yo ka fè ak mayi ankò ?

Leson 104

M ap pare tout zafè m avan lè pou mwen pa anreta.



rekreyasyon



egzamen



Alè,

Mwen pare tout bagay davans

Alè,

M ap leve bonè, mwen p ap pran chans

Alè,

M ap mache, m ap prese paske

Alè

Mwen dwe rive !



bay sipriz egzamen korije

poze reponn konpoze leson fò

kesyon



Timoun yo te byen reponn kesyon yo.

Joslin fò nan fè adisyon detèt.

Leson 105

Mwen respekte prensip lekòl mwen.

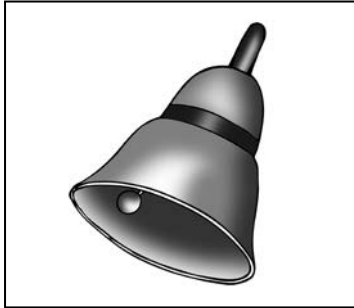

klòch

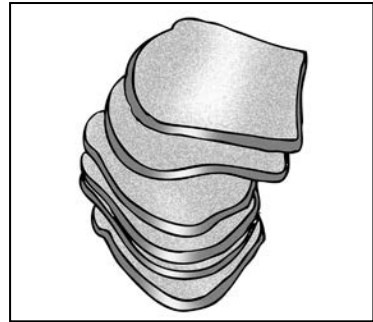

tranch pen



Lekòl se la mwen santi m byen.

Lendi jiska vandredi mwen prezan.

Mwen p ap rate yon jou.

Mwen pral lekòl alè.

M ap fè devwa m yo.

M ap etidye leson m yo.

Lekòl se pa m, mwen p ap rete lakay.



klòch prensip silans seri tranch

dezidrate sewòm lave san zèb



Mis la mete sewòm nan pou Ejèn.

Direktè a ap sonnen klòch la.

Lave men (istwa 1)

Nan maten, pandan Jilyen ap sekle vye zèb nan lakou a, li manje yon tranch pen mayi san li pa lave men li. Nan apre midi, li gen dyare. Sa lakòz li dezidrate. Manman



li ba li sewòm oral nan aswè. Depi jou sa a, Jilyen toujou lave men li anvan li manje.

Kesyon

1. De kilès istwa a pale ?
2. Site youn apre lòt tout aktivite Jilyen fè ?

Lekòl Kasann nan (istwa 2)



Kasann al lekòl Lakolin. Chak maten, anvan li rantre nan klas li, gen yon seri aktivite li dwe fè. Premyèman, li klòch la sonnen, li mete li an ran. Dezyèmman, li chante im nasyonal la pou monte drapo. Twazyèmman, li antre nan klas la an silans pou li travay. Finalman, li kòmanse travay. Kasann respekte tout prensip lekòl la.

Kesyon

1. Ki moun ki respekte tout prensip lekòl la ?
2. Site youn apre lòt tout aktivite li te fè ?

Leson 106

M ap eseye jiskaske mwen reyisi.

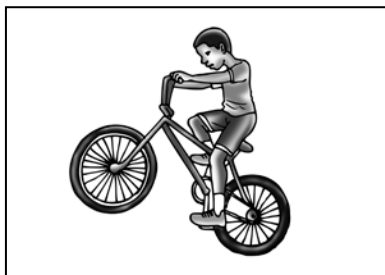

defi

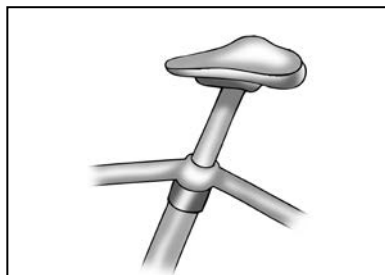

sèl



Mwen p ap dekouraje,
M ap eseye jiskaske mwen rive.
Menm si mwen tonbe, m ap leve.
M ap rive kanmen m.



gran eseye fwa domaj dwat
pedale defi chagren vin monte



Li pedale vit.
Alis vin manje byen ta.

Leson 107

Mwen pa twò prese, m ap tann lè mwen.

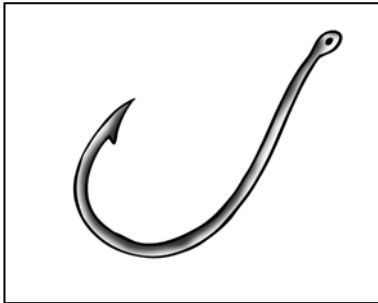

kwòk zen

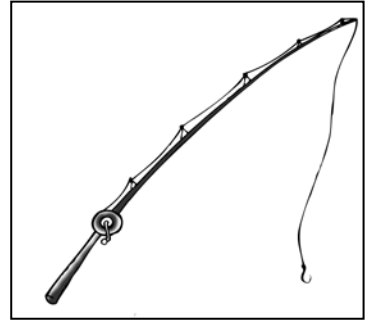

zen



Douvan jou mwen leve,
Mwen pran kannòt mwen, m ale peche.
Nas mwen ak zouti mwen bò kote m.
Mwen nan mitan lanmè m ap navige.
Ak pasyans m ap jwenn pwason.



peche lanmè kal kannòt
pwason gwo zen kouraj zouti
rale



Pwason an gen kal sou kò li.
Pechè a retire zen an nan bouch pwason an.

Layens, yon gran pechè



Layens se pechè. Li pa al peche lè gen move tan. Yon jou, lanmè a te poze, li pran kannòt li, li ale peche. Pou kòmanse, li mete zouti li bò kote li. Apre sa, li voye liy li. Yon gwo pwason pran nan zen an. Layens rale li men pwason an fè fòs. Alafen, gras ak kouraj li, li kenbe pwason an.

Kesyon

1. Ki jan yo rele pechè a ?
2. Ki lè li pa al peche ?
3. Site 2 zouti Layens ka itilize pou l peche ?
4. Ki premye aksyon li te fè ?

Leson 108

Mwen ka ede moun ak bon jès.

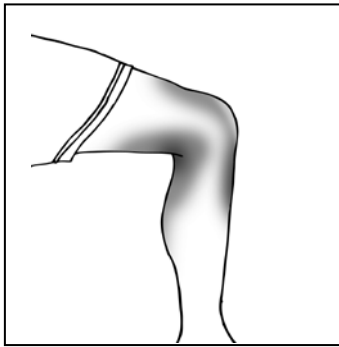

jenou

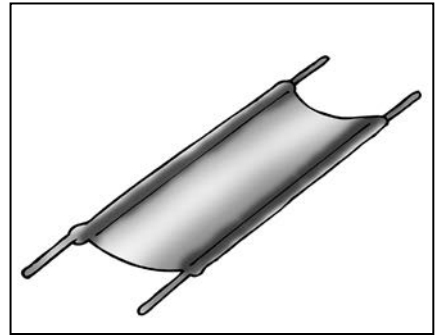

branka



Mwen gen kè sanbib

Depi yon moun gen yon pwoblèm

Mwen toujou prè pou mwen ede l.

Mwen ede timoun kou granmoun.

An nou sipòte youn lòt.



annuiye

jwe

menm

frape

retire

sansib

respekte

basketbòl

soutni

mennen



Ti fi tankou jèn gason ap jwe basketòl sou lakou a.

Dafi respekte tout prensip lekòl la.

Leson 109

Jwèt se jwèt, mwen p ap mande goumen si
mwen pèdi.

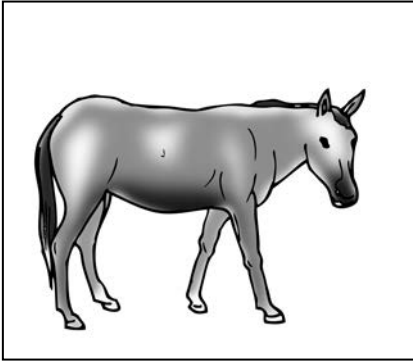

patiraj

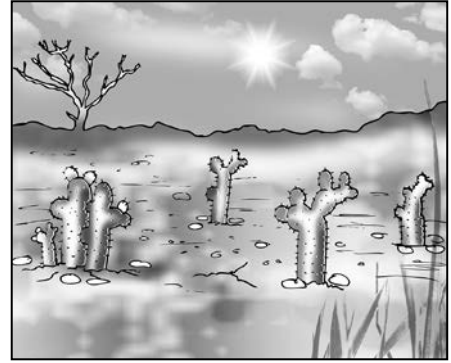

bèt



Chak moun gen jou pa yo.

Si jodi a se tou pa m,

Demmen se ap tou pa w.

Mwen kontan lè se tou pa yon lòt.

Lè n ap jwe tout moun ka genyen.



kous konte rive trase move

genyen lòt ka liy milèt



Vòltè konn monte milèt.

Tanya ap konte jwèt li yo.

Kous cheval ak milèt

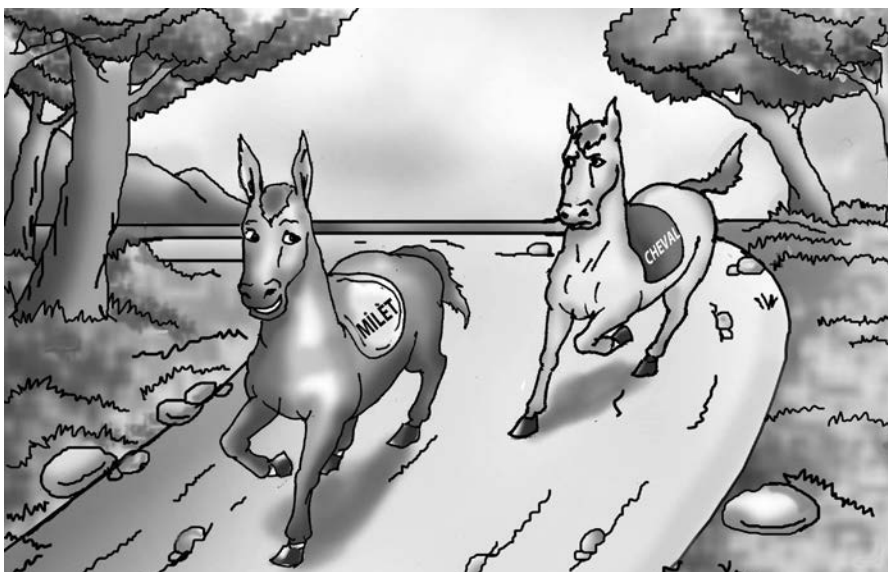

Yon jou, cheval ap fè yon kous ak milèt. Li genyen l. Nan demen, Milèt mande Cheval yon kous. Pou kòmanse, milèt trase liy kote kous la ap rive a. Apre sa, cheval ak milèt konte rive sou 4, yo kouri. Alafen, milèt genyen kous la. Cheval move. Li panse se li ki te dwe genyen. Milèt di li :

« Se pa ou ki dwe toujou genyen. Yon lòt ka genyen w tou. »

Kesyon

1. Kilès k ap fè kous la ?
2. Pou ki sa milèt la trase liy la ?
3. Kilès ki genyen kous la ?
4. Èske nou konn fè jwèt kous ak zanmi nou ? Ki jan sa konn pase ?

Leson 110

M ap vwayaje ale nan lòt zòn pou mwen dekouvri peyi m.

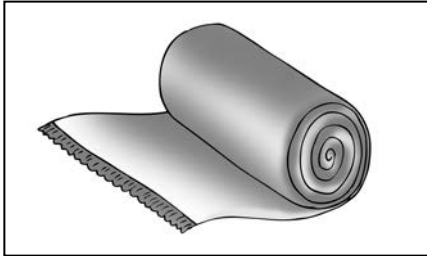

sèvyèt

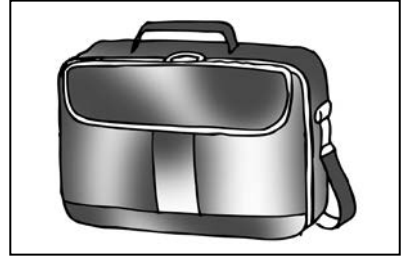

valiz



Nan Sid mwen prale.

Mwen pral vizite.

Mwen pral manje anpil pwodui lakay.

Dous makòs ap ret tann mwen Tigwav.

Kavayon m ap manje yon bon pen ak jele.

Nan vil Okay, m ap jwenn anpil tablèt kokoye.

Nan Sid mwen prale.



lavèy malèt kamyon bri sèvyèt

klaksòn estasyon malèt savon

monte



Remi se chofè kamyon.

Florans kanpe nan estasyon kamyonèt la.

Leson 111

Zwazo ak flè se richès lanati.



flanbwayan



wanganègès



Mwen se zwazo.
mwen gen bèl plimay.
M ap vole toutapou,
Poze sou tout pyebwa,
Chante tout kalite chante.
Mwen se zwazo,
Mwen itil tankou tout lòt bèt.



kolonn wanganègès nich kout
ponn petit flanbwayan branch
sanble tounen



Manman poul la ponn 6 ze.
Pye flanbwayan an chaje ak flè wouj.

Wanganègès

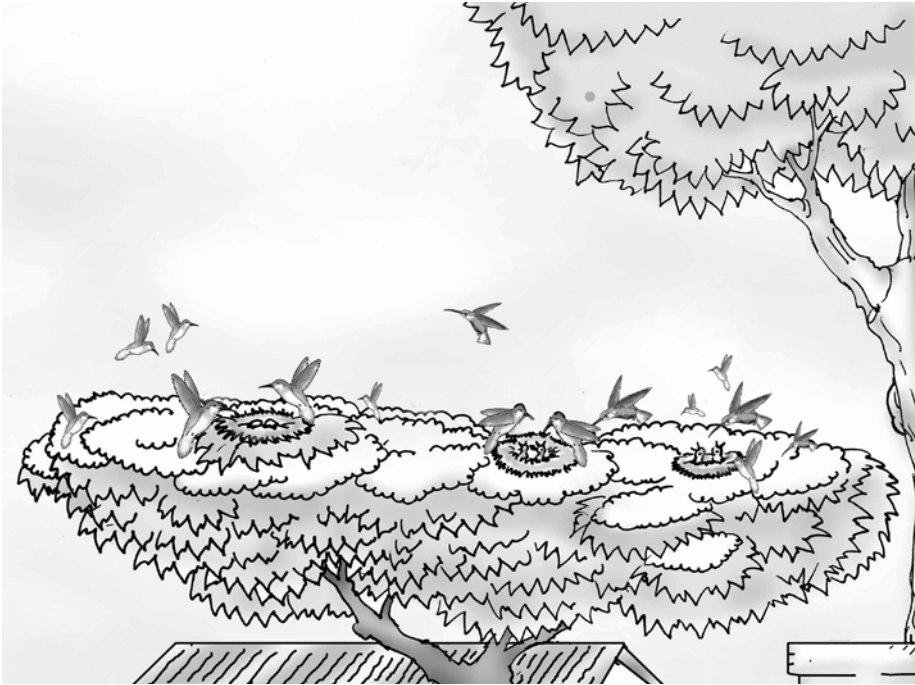

Yon lè, yon kolonn wanganègès bezwen ponn. Toudabò, yo deside fè nich yo sou yon pye flanbwayan. Apre sa, yo ale chèche fèy ak ti branch bwa. Yo sanble yo pou fè nich. Finalman, yo ponn. Nan yon ti tan tou kout, pye flanbwayan an chaje ak pitit wanganègès. Pye flanbwayan an tounen kay wanganègès yo.

Kesyon

1. De ki zwazo istwa a pale ?
2. Ki sa yo te bezwen fè ?
3. Ak ki sa yo fè nich la ?
4. Èske nou renmen istwa sa a ? Pou ki sa ?

Leson 112

Mwen dwe ede moun ki nan bezwen.

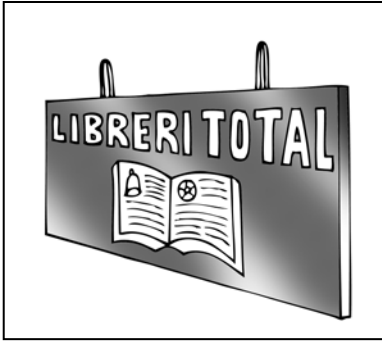

pankat



achte



Yon timoun obeyisan
Tande konsèy paran
Yon timoun obeyisan
Toujou fè sa ki bon
Yon timoun obeyisan
Toujou jwenn anpil konpliman.



komisyon felisite boutik malad
pote bliye kabann benyen fèy
deplase



Jinèt pote yon komisyon kay grann li.
Papa Jino felisite l pou jan li byen li istwa a.

Leson 113

Mwen p ap bati kay mwen nenpòt kote.

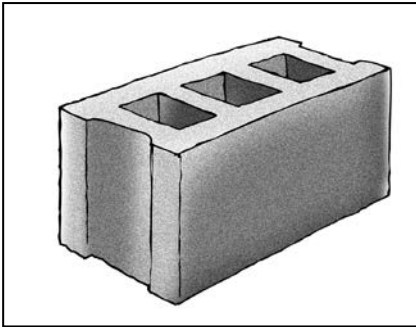

blòk

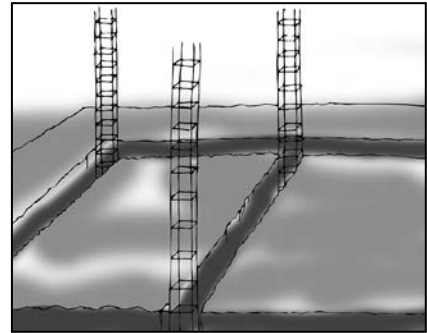

fondasyon



Malè pa gen klaksòn.

Aksidan pa janm avèti.

Mwen p ap bati bò ravin.

Mwen p ap bati bò falèz.

Prekosyon pa kapon.



fondasyon fouye baz bati

kouvri satisfè mason ravin

rivyè blòk



Enèl kouvri tab la ak yon nap.

Jilya ta renmen vin bòs mason.

Yon bon bòs



Remi se bòs mason. Li pa janm bati kay ni bò ravin ni tou pre rivyè. Yon lè, bòs Remi ap bati yon kay pou Masèl. Toudabò, li fè fouye fondasyon an epi li fè baz kay la. Apre sa, li monte blòk yo. Finalman, li kouvri kay la. Kay la byen kanpe. Masèl satisfè.

Kesyon

1. Kòman yo rele bòs mason an ?
2. Ki kote bòs Remi pa janm bati kay ?
3. Pou ki moun bòs Remi t ap bati kay la ?
4. Di 3 aksyon bòs Remi fè youn apre lòt pou li bati kay la ?

Leson 114

Mwen p ap gaspiye dlo.



tiyo



klowòks



Wololoy! Gade dlo !

Se pa ti dlo, nan vil Sodo.

Dlo agogo.

Tout veso plen ak dlo.

Tiyo vini, tout basen gen dlo.

Nou p ap gaspiye dlo,

Menmsi dlo agogo.



gaspiye bokit siveye zanmi tiyo

dlo rad enpòtan lave benyen



Manyela pa gaspiye anpil dlo lè l ap benyen.

Mayòt di Papouch pa lave rad li yo anba

tiyo a.

Leson 115

Mwen p ap pran anyen nan jaden yon moun
si li pa ban mwen pèmisyon.

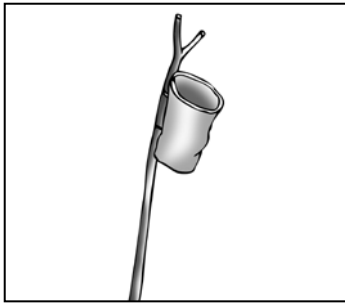

gòn



plim



Anlè tèt nou zwazo

Ap vole san rete, y ap chante

Anba dlo tout pwason ap danse

Pandan bèt kat pat yo

Ap ranni, ap jape, ap rele san repo

Mezanmi ! Pa gen lavi san zannimo !

An n pwoteje yo !



gòn lakou lonje mango san
dwa gra konnen jij diskisyon



Anèt ap keyi mango ak yon gòn nan lakou a.
Jij Chantal mande moun yo pou yo sispann
fè diskisyon.

Andre ap keyi mango (Istwa 1)

Yon jou, Andre al keyi mango kay bòs Danyèl. Pou kòmanse, li pran gòl li epi li antre nan lakou a. Apre sa, li lonje gòl la, l ap keyi mango. Bòs Danyèl vin parèt. Li di Andre :

- Ki moun ou te mande pou ou keyi mango ?

Andre reponn :

- Pèsòn.

Alafen, bòs Danyèl fè li konnen li pa gen dwa antre nan lakou moun pou vin pran bagay san mande.

Kesyon

1. Kilès ki te al keyi mango kay bòs Danyèl ?
2. Site youn apre lòt tout sa Danyèl te fè ?



Kaw ak zòtolan (Istwa 2)



Kaw ak Zòtolan pete yon diskisyon pou konnen kilès ki pi gra. Toudabò, Kaw mande Zòtolan kouman li fè mèg konsa. Apre sa, Zòtolan di kaw : « Ou pa pi gra pase sa. Se anpil plim ou genyen. » Finalman, yo rele Chat vin fè jijman an. Chat di : « Mwen poko manje ni Kaw ni Zòtolan. »

Kesyon

1. Kilès ki te nan diskisyon an ?
2. Site youn apre lòt tout pawòl ki te di yo ?

Leson 116 Revizyon

M ap kenbe pwomès mwen.



Kliyan m se pa m.

Mwen p ap fè yo mache pou granmesi.

M ap kenbe pwomès mwen.

Kit mwen se bòs mason,

M ap kenbe pwomès mwen.

Kit mwen se mekanisyen,

M ap kenbe pwomès mwen.

Kilyan m se pa m.

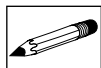

twal fi modèl mezi tay

randevou prè sèsò koud longè



Manman mwen achte yon bèl twal.

Ton Eli gen randevou kay doktè a.

Leson 117 Revizyon

Mwen p ap jwe nenpòt kote.



Woule sèk se jwèt.

Tire wòch pa jwèt.

Domino, teke mab, sote kòd,

Yo tout se jwèt

Men jwèt ki gen danje pa ladan !

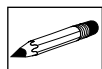

renmen vandredi tamaren kache

pwoteje swa fon vwa lago

pè



Sizèt renmen manje tamaren.

Chat Jid la pè, li kache byen fon.

Lago kache

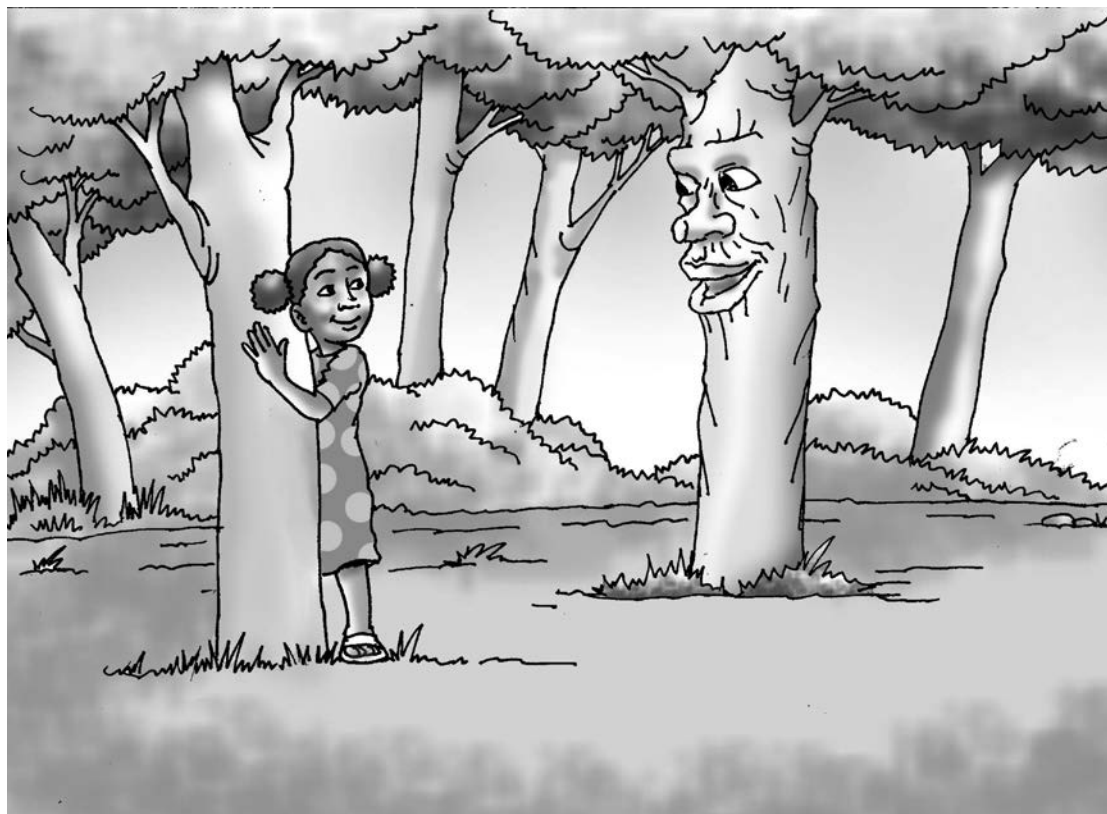

Silfiz renmen fè lago kache. Yon vandredi swa, pandan li al kache nan fon jaden an, li tande yon vwa ki di l : « Vin kache la pito. » Silfiz pa wè moun nan. Li pè. Vwa a pale ankò : « Se mwen, Pye tamaren an k ap pale ak ou. » Silfiz ale pou li kouri. Pye tamaren an di li : « Pa pè. Tout pyebwa se zanmi timoun. Se poutèt sa nou dwe pwoteje yo. » Depi lè sa a, Silfiz toujou kache anba pye tamaren an.

Leson 118 Revizyon

M ap pran tout prekosyon lè gen move tan.



Vouououou ! Gwo van ap soufle
Brrrrrrrrrrrrrrrrrrrr ! Branch bwa kase
Blogodop! Loraj gwonde.
Lapli pa sispann tonbe.
Sa a se yon siklòn !
Prekosyon pa kapon !



fawouche konsantre ouragan
derasinen branch fòs van fòk
atè zèb



Fòs van an derasinen pyebwa yo.
Kabrit la ap manje zèb atè a.

Ti van

Ti van pa t
konn ki jan pou
li soufle fò.
Tout plant yo
te toujou ap
fawouche l, di li
se pa pou anyen
yo rele l Ti van.

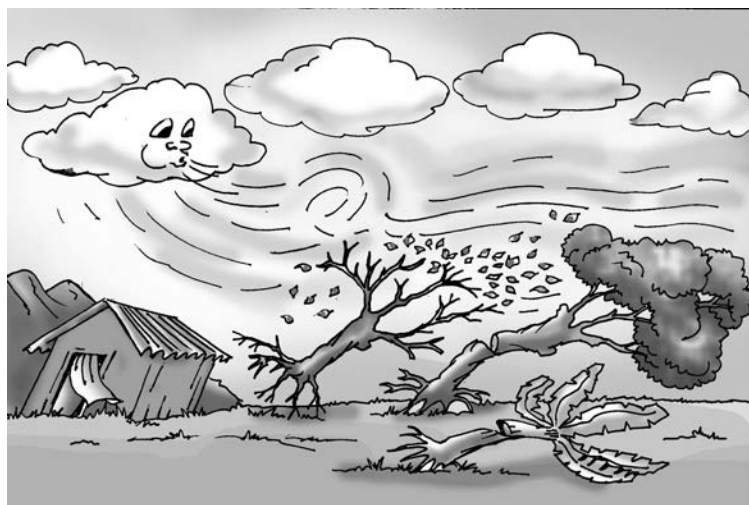

Yon jou, Ti van deside fòk li soufle fò kanmenm.
Toudabò, li rete konsantre pandan plizyè jou pou
kenbe souf li. Apre sa, lè li pa kapab ankò, li gonfle
bouch li epi li soufle ak tout fòs li. Plant yo sezi,
branch bwa kase, pye bwa derasinen, tout ti zèb
kouche plat atè. Lè Ti van fini, li wè kote a pa bèl
ankò. Finalman, Ti van pa janm soufle fò ankò. Men
depi lè sa, plant yo ba li non « Ouragan ».

Kesyon

1. De kilès istwa a pale ?
2. Ki sa Ti van pa t ka fè ?
3. Ki sa plant yo te fè ?
4. Site tout etap Ti van pase pou li rive soufle fò ?

Leson 119

M ap pwoteje tout sa ki sou plas yo

Tèks teyat

Sèn 1

Naratè : 24 desanm nan maten, jèn nan katye Wayal deside netwaye plas la. Toudabò, yo bale plas la. Answit yo pentire l. Alafen yo dekore li ak anpil limyè. Se pa ti bèl plas la te bèl ! Men gen yon ti gason k ap ekri sou ban yo ak yon kreyon desen.

Chèlin (*mache vit, l ap pale ak li*)

Tèkito, pou ki w ap sal ban nou sot pentire yo ?

Tekito (*reponn byen vag*)

Ban yo se lakay ou yo ye ! O o se ban leta yo ye
wi !

Mwen ka fè sa m vle ak yo.

Chèlin (*sezi*)

An han ! Konsa menm !

Depi yon bagay pou leta ou ka kraze l ak detwi l ?

Leson 119

Tèkito (*tèk tèk*)

Se sa li ye menm ! Ou pa t konn sa.

Chèlin

Se ak lajan paran nou wi leta fè plas la.

Tèkito (*l ap desinen sou ban yo, li pa vire gade Chèlin*)

Mwen pa kwè nan koze sa a.

Naratè : Tèkito kontinye ekri sou ban yo. Kòm Pè Riche rete tou prè plas la, Chèlin kouri al rele l pou l ka pale ak Tèkito.

Leson 120

M ap pwoteje tout sa ki sou plas yo.

Naratè : Chèlin ak Pè Riche ap mache prese prese. Lè Pè Riche rive li sezi wè jan Tèkito ap sal ban yo.

Pè Riche (*min li mare*)

Tèkito, sa w ap fè la ?

Tekito (*pantan*)

O !

Chèlin

Se pa « O » non. Se Pè Riche.

Pè Riche (*ton serye*)

Tèkito, pitit mwen, plas la se pou nou. Nou dwe kenbe li pwòp.

Chèlin (*l ap fè bas*)

Mwen te di l sa.

Tèkito (*serye*)

Pè Riche, plas la se pou leta li ye.

Mwen ka fè sa mwen vle sou li.

Pè Riche

Leta se mwen, se ou, se tout moun k ap viv nan zòn nan. Kidonk nou dwe pwoteje ak respekte tout sa leta genyen.

Se pou nou yo ye, yo itil nou.

Tèkito (*etone*)

Pè Riche, mwen te nan erè.

Chèlin

Ou pa t konprann anyen nan anyen, monchè !

Pè Riche

Pitit mwen yo, toujou sonje,
tout sa leta konstwi se pou benefis ak enterè
kominote a.

Epitou, tout sa ki nan zòn nan se fyète
ak diyite nou.

Tèkito

Sa a se vre ! ou gen rezon Pè Riche. Ban m al
netwaye ban mwen te sal yo.

Naratè : Se konsa Tèkito ansanm ak lòt jèn yo kontinye netwaye plas la. Plas la bèl. Pita nan aswè tout timoun t ap jwe sou plas la. Se te bèl fèt.

Leson 121

M ap respekte sa zanmi mwen yo panse.

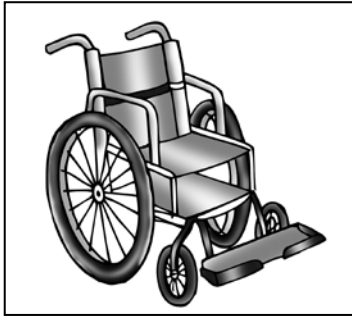

chèz woulant

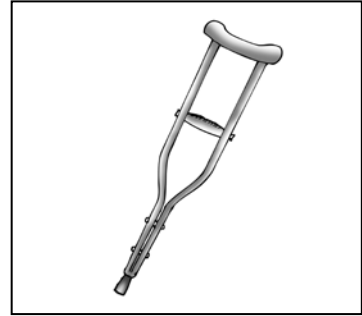

beki



Mwen se yon gason

Men mwen pa jèn, mwen se yon granmoun

Timoun renmen m epi yo respekte m

Pafwa mwen se papa manman m

Pafwa mwen se papa papa m.

Mwen se _____.



blanch bab pwoblèm antouraj

mache bò min jan pip boude



Jozafa boude epi li mare min li.

Misye bab blanch la gen bon jan.

Leson 122

Malgre difikilte, m ap toujou fè efò.

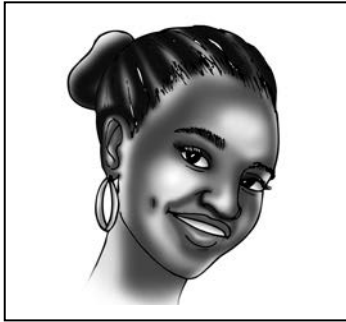

toubote



inondasyon



Mwen nan vizaj ou depi lè ou tou piti.
Malgre w ap grandi m ap toujou la.
Depi ou souri mwen parèt bò bouch ou.
Gen anpil moun ki renmen m.
Mwen se de ti twou bò bouch ou.
Mwen se _____.



lespwa kannèl inondasyon
toubote vizaj bèl souri pèdi
sispann chagren



Inondasyon ka fè gwo dega.
Malin gen de toubote sou vizaj li.

Mariliz

Mariliz gen cheve kannèl. Li gen bèl souri ak de toubote nan figi li. Men sa fè kèk tan Mariliz sispann ri. Kè li pa kontan. Li te pèdi tout byen li nan yon gwo inondasyon. Samdi maten, Matilya, pitit pitit Mariliz vin wè li. Matilya kout epi li gen bèl cheve grenn. Li pa renmen wè lè grann li chagren. Li di grann li : « Ou toujou aprann mwen depi gen lavi ap toujou gen lespwa. » Pawòl sa a fè grann nan souri. Matilya di : « Grann Liz mwen ta renmen gen yon bèl souri menm jan ak ou. »



Kesyon

1. Kilès ki te gen cheve kannèl nan istwa a ?
2. Ki sa ki te lakòz Mariliz te pèdi tout byen li ?
3. Ki sa Mariliz te di grann li Matilya ?
4. Pou ki sa daprè nou Mariliz te tonbe ri ?

Leson 123

Mwen ta renmen brav menm jan ak endyen yo.



anati

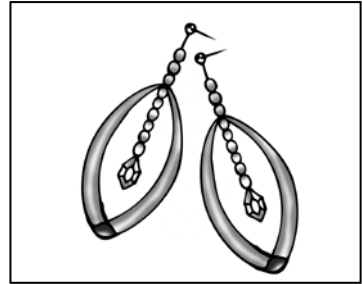

zanno



Mwen gen cheve long epi yo siwo
Mwen gen koulè wouj
Mwen mache do touni ak yon ti jip sou mwen
Mwen te renmen viv nan forè
Espanyòl yo te konn fè m travay di.
Mwen se _____.



brav pwezi vanyan jansiv
lestomak wotè figi renmen cheve
kontan



Patrik gen bèl wotè.
Nadèj ekri yon bèl pwezi pou papa ak
manman li.

Leson 124

M ap ede moun nan zòn mwen.



konbit

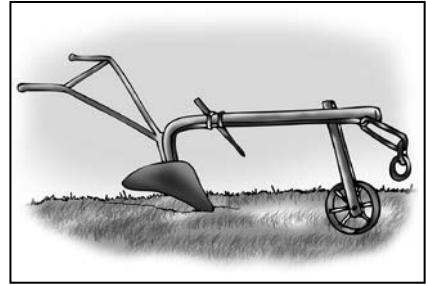

chari



Se yon pati nan kò moun

Mwen pa pye mwen pa bra

Aaa mwen pa vant non plis

Mwen gen 2 je, 2 zorèy,

Bouch, nen ak cheve

Tout bagay sa pote yon sèl non.

Mwen se _____.



toujou granmoun konbit ankò ede

kout chèf ale zòn kòmanse



Sofya ap travay nan jaden an.

Jakòb se yon gwo chèf konbit.

Yon ansyen chèf konbit

Jaklen se moun Kapwouj. Li gen gwo ponyèt. Figi li won epi cheve li blanch. Depi te gen konbit yon kote, Jaklen te toujou la. Li te yon chèf konbit ! Kounye a, Jaklen vin granmoun. Li pa ale nan konbit ankò. Men Jaklen genyen yon bon zanmi li ki rele Estavyo. Estavyo



kout, epi cheve li kòmanse blanch. Se li ki vin chèf konbit nan zòn nan. Estavyo ak Jaklen toujou ap pale sou jan sa bèl lè youn ede lòt nan zòn nan.

Kesyon

1. Dapre istwa a, kilès ki te gen figi won ?
2. Ki kote l ap viv ?
3. Ki travay Jaklen te konn fè ?
4. Kòman yo te rele bon zanmi Jaklen an ?

Leson 125

M ap travay pou mwen ka reyisi.

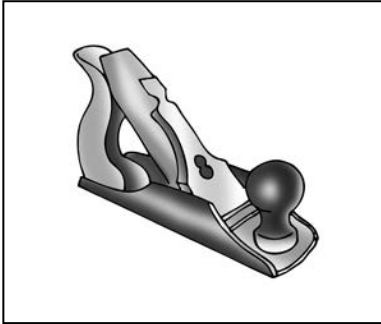

rabo

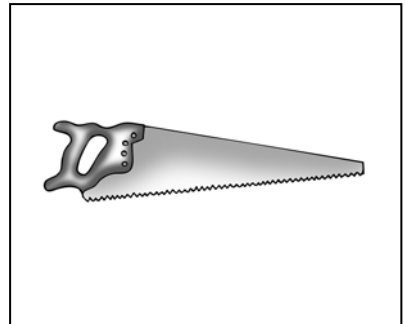

goyin



Lè w travay anpil ak men w
Mwen parèt nan dwèt ou
Mwen tankou yon blad
Ki pa gen van men ki plen dlo
Mwen fè w mal lè ou peze m.
Mwen se _____.



atelye	pito	bòs	goyin
planch	rete	mens	etidye
katye	siye		



Bòs Sipriyen ap travay nan atelye a.
Timoun sou katye a renmen jwe ansanm.

Leson 126

M ap apresye travay kiltivatè yo.



biznismann

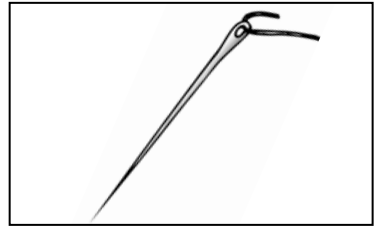

zegwi



Zanmi mwen se plant, fimye ak lapli
Mwen bay moun manje
Yo toujou ap siveye mwen pou bèt
Ak zwazo pa vin manje mwen
Mwen se kote apa yo simen
Tout kalite grenn pou bay fwi.
Ki sa mwen ye ?
Mwen se _____.



debake kamyon biznismann
pwodui peyizan chankre achte
lavil pou ankouraje



Biznisman yo achte pwodui nan men peyizan
yo.
Flavi mete machandiz yo nan yon gwo
kamyon.

Yon gwo biznismann



Wodrig se yon mesye fen tankou zegwi. Li gen anpil bab epi tèt li chankre. Wodrig toujou ap monte desann. Se biznismann li ye. Tout moun nan kanton an konnen li. Chak semèn li debake Lestè. Li achte pwodui nan men peyizan yo. Apre sa li chaje yo sou yon kamyon pou li mennen yo lavil. Li toujou ankouraje peyizan yo travay latè epi bay pi bon pwodui.

Kesyon

1. Ki jan yo rele gwo biznismann nan ?
2. Ki bò Wodrig ale achte ?
3. Ki sa Wodrig fè lè li fin achte ?
4. Ki sa Wodrig ankouraje peyizan yo fè ?

Leson 127

M ap pran prekosyon lè m ap travèse lari.

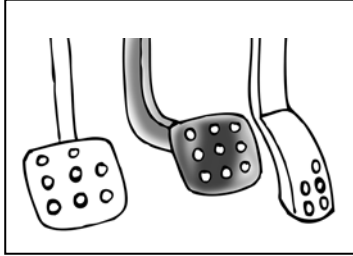

fren

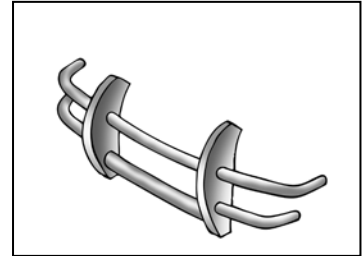

defans



Kikik ! Kikik ! Kikik ! Kikik !

Yo mete m nan machin

Nan bisiklèt ak nan motosiklèt

Yon bon chofè pa ta dwe kondui san mwen

Mwen se yon pyès enpòtan

Chofè yo toujou sone m pou avèti danje.

Mwen se _____.



kamyonèt klaksòn frennen

atansyon tèt sou sèk fòk

reflechi men



Mantout sonnen klaksòn nan avan li
frennen.

Sonèl renmen mete men li sou tèt li lè l ap
reflechi.

Leson 128

M ap jwe ak bèt lakay mwen yo.

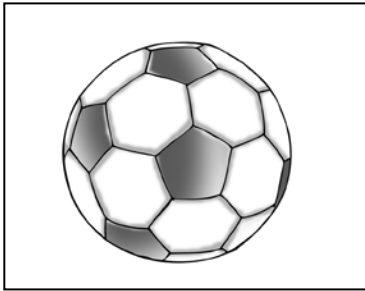

balon

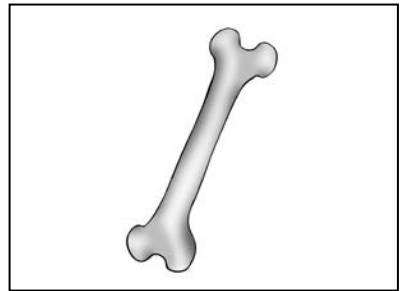

zo



Gade zo nan asyèt la !

Mwen renmen manje zo

Woup ! Woup ! Woup !

Lajounen kou lannuit m ap siveye

M ap siveye tout sa mèt mwen genyen

Lè mwen wè yon moun mwen pa konnen
mwen jape.

Mwen se _____.



pwoteje zanmi achte mòde foule

kay won bon pou laj



Natali achte tòl pou li kouvri kay li a.

Zanmi Pyewo a foule nan dwèt.

Ti chen Bòb la



Bòb se yon ti gason kout foule. Tèt li won. Figi l laj epi li gen bèl cheve grenn. Bòb gen yon ti chen li rele « Doula ». Doula se bon zanmi l. Bòb achte yon boul pou li jwe ak Doula. Lè konsa yo kouri ak boul la nan tout kay la. Doula mòde ti boul la. Li voye li adwat, agoch. Antouka, Bòb renmen Doula anpil, se pou sa li toujou pwoteje l.

Kesyon

1. Kòman ti chen Bòb la rele ?
2. Ki kote Bòb ak ti chen an konn jwe ?
3. Ki jwèt yo konn fè ?
4. Pou ki sa Bòb toujou pwoteje Doula ?

Leson 129

Plant yo fè mwen respire byen, m ap toujou pran swen yo.

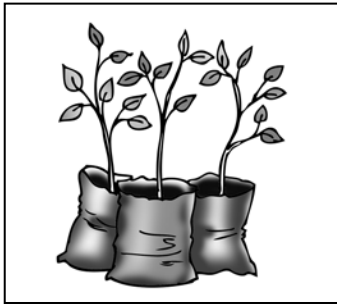

pepinyè

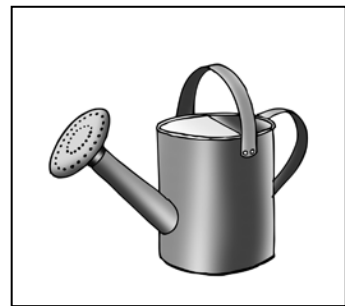

awozwa



Mwen pa tè, mwen pa plant
Mwen itil anpil pou plant yo
Yo fè m ak tout kalite pwodui
Lè yo mete m nan tè a mwen fè
Plant yo grandi vit epi bay bon fwi.
Mwen se _____.



angrè wouze plant pèmèt
lajounen frè zèb klè très respire



Ànmari mete angrè nan rasin plant yo.
Elibè ap rache zèb bò pi a.

Leson 130

M ap fè desen tout bèl bagay ki gen nan peyi mwen.



penso



penti



Mwen se yon atis

Mwen pa konn jwe mizik

Mwen pa konn chante

Men metye mwen se fè bèl desen

Ak bèl tablo pou dekore kay.

Mwen se _____.



tablo mòn galri penti zwazo

kouche dimanch plaj syèl

desen



Zwazo yo al kouche sou tèt mòn yo.

Katyana kouche paske li fatige.

Yon atis pent



Jozefin gen dizan. Li gen cheve boukle. Pye li yo long. Ou pa ta di nenpòt demwazèl kenzan. Jozefin ta renmen vin yon gwo atis pent. Chak apre midi, avan solèy kouche li pran penti ak penso li pou li kòmanse desine. Li fè desen ti zwazo k ap vole nan syèl la. Li fè desen plaj, rivyè ak mòn yo. Lè dimanch, li mete tout tablo li yo sou galri lakay li. Tout moun te kontan wè bèl tablo Jozefin te fè.

Kesyon

1. Ki moun ki ta renmen vin yon gwo atis ?
2. Ki sa li fè chak apre midi ?
3. Ki desen li fè ?
4. Ki jou li mete tablo yo sou galri a ?

Leson 131

Mwen bezwen atansyon ak pwoteksyon.

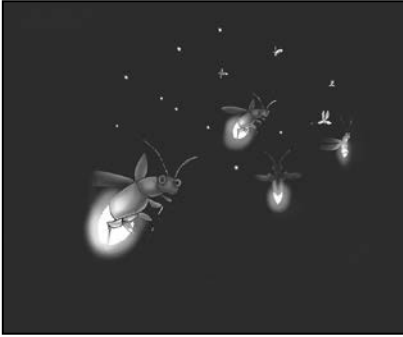

koukouy



kapon



Mwen gen 2 wou

Mwen kouri nan bon wout

Mwen kouri nan move wout

Tout timoun renmen kondui m

Fòk ou pedale mwen vit si w vle m ale fò.

Mwen se _____.



medikaman wout soulaje lannuit

plas malad rankontre kè rezon

kalite.



Neyèl malad, lestomak li ap fè li mal.

Nawomi pa mache lannuit poukont li.

Leson 132

Mizik se bèl bagay. M ap aprann jwe yon enstriman mizik.



batri



mikwo



Pwoche vin tande bèl mizik.

M ap fè tout moun danse.

Mwen se yon mizisyen.

Mwen konn jwe gita.

Se gita m ki pi bon zanmi m.

Mwen se _____.



mizisyen mizik enstriman moso

gita wè danse sezi felisite abiye



Mizisyen an fè jounen l ap jwe san li pa fatige.

Jèn yo sezi wè jan granmoun nan gen fòs toujou.

Makso, yon bon mizisyen



Makso se mizisyen. Li jwe gita byen. Se pa ti bòzò li bòzò lè l ap jwe gita. Dayè li gen bèl wotè epi li toujou byen abiye. Yon jou Makso t ap jwe gita nan yon fèt. Li fèmen de je li epi l ap danse. Apre chak mizik li fin jwe li fè yon ti bo pou gita a. Lè fèt la fini, Makso pran yon ti moso twal blanch, li siye gita a byen siye epi li mete l nan bwat. Tout moun bat bravo pou Makso epi yo felisite l pou jan li renmen enstriman an.

Kesyon

1. De kilès istwa a pale ?
2. Ki sa li konn fè ?
3. Ki jan Makso ye lè l ap jwe gita a ?
4. Pou ki sa tout moun felisite Makso ?

Leson 133

Tout vwazen ap ede mwen paske mwen gen bon jan.



wont



lanmè



Yo fè m ak papye oswa an metal
Yo mete m labank oswa nan bous
Moun sèvi avèk mwen pou yo achte sa yo
vle.

Mwen se _____.



mwayen kòb saj fanmi rekòmanse
kontan mal renmen katye lapenn



Ton Eli renmen fanmi li.
Adlin gen kòb pou li achte fresko.

Leson 134

Agwonòm yo enpòtan anpil nan agrikilti peyi mwen.



angrè

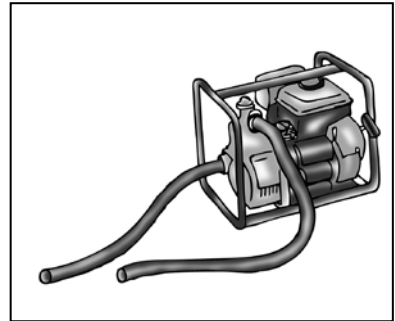

ponp dlo



Mwen pase tout tan m nan jaden mwen
Mwen renmen plante pye bwa
Mwen renmen lè lapli tonbe
Pou jaden mwen ka wouze
Pwofesyon mwen se fè agrikilti.
Mwen se _____.



fèmen agwonòm pwovens kagou
tèlman dizan gran sonje
pafwa renmen



Agwonòm yo al travay an pwovens.
Patrisya renmen viv ak kè kontan.

Nadya, yon agwonòm anvan lè



Nadya se yon ti fi dizan. L ap viv Pòtoprens. Li ta renmen vin yon agwonòm lè li gran. Depi lekòl fèmen, se toujou avèk anpil kè kontan li ale an pwovens. Li pran plezi nan fè jaden ak granpè li. Lè konsa, Nadya pa sonje Pòtoprens tèlman li renmen jan moun yo viv an pwovens. Chak sa li wè, li poze granpè li kesyon. Menm si pafwa granpè a vle kagou, li toujou reponn kesyon Nadya yo.

Kesyon

1. De kilès istwa a pale ?
2. Ki bò l ap viv ?
3. Ki sa li ta renmen vin ye lè li gran ?
4. Pou ki sa ou panse Nadya poze granpè li kesyon ?

Leson 135

M ap pran swen jwèt mwen yo.



poupe



nounous



Mwen fèt an plastik oswa an twal

Pafwa mwen chante

Pafwa mwen pa chante

Pafwa mwen gen fòm ti fi

Pafwa mwen gen fòm ti gason

Ti fi renmen jwe avè m.

Mwen se _____.



benyen dlo gaya jwe pi kriye

chagren mennen penyen pandan



Majori ap benyen ak dlo tiyo.

Nadèj penyen anvan li chanje rad sou li.

Leson 136

M ap jwe foutbòl chak jou pou m ka vin pi fò.

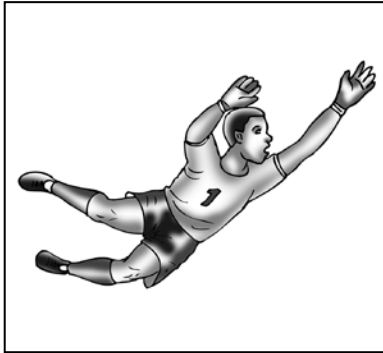

gadyen



chenè



Mwen se yon jwè foutbòl

Mwen pa make, mwen pa bay gòl

Responsabilite mwen se anpeche

Ekip mwen pran gòl

Plas mwen sou teren an se anba kan an.

Mwen se _____.



foutbolè chenè boul gòl pase

drible rakonte make konpliman

match



Matilya se yon gwo foutbolè.

Toni ap fè chenè ak boul Faniz la.

Yon bèl ekip



Vlad se premye pitit gason mesye misye Vandal ak madanm li. Li mens. Cheve li nwa. Lòt jou, Vlad ak papa li te jwe yon ti match foubòl nan lakou lakay yo a. Vlad pran boul li. Li kòmanse fè chenè. Lè papa li vin make li, li drible l. Li drible agòch kou adwat. Li menm pase balon anba janm papa l. Apre sa, li choute, li fè yon gòl. Li tèlman kontan li vole nan kou manman li. Manman an souri. Li di Vlad : « Konpliman, ou se yon gwo jwè foubòl. »

Kesyon

1. Ki sa Vlad ak papa li te fè lòt jou ?
- 2- Ki sa ki montre Vlad pi fò pase papa li nan foubòl la ?

Leson 137

M ap aprann pataje sa mwen genyen ak lòt yo.



krèm

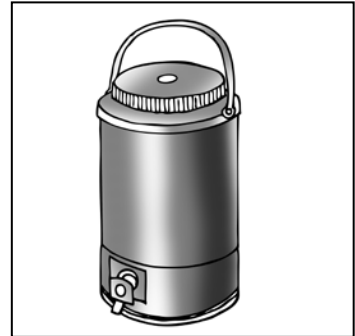

tèmòs



Mwen pa fresko

Mwen fèt ak tout kalite fwi.

Yo mete m nan frijidè pou mwen glase.

Yon vann mwen nan kèp,

Nan sachè oswa nan kònè.

Timoun renmen bwè mwen.

Mwen se _____.



krèm eseye mouch atè mare

separe min glase chich flannen



Krèm nan byen glase.

Antoni separe ren pou ren manje li a ak ti frè li a.

Leson 138

M ap pran swen paran mwen yo lè yo malad.

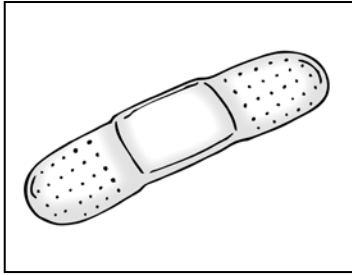

pansman



anbilans



Mwen se yon fi, mwen janti anpil.

Mwen abiye toudeblan

Pou m ale travay.

Yon kwaf blan sou tèt mwen.

Mwen travay nan lopital.

Metye m se pran swen moun ki malad.

Mwen se _____.



remèd pwawo gaz malad

anpare soufri vant mèt apeti

prepare



Polo gen kè sansib li pa renmen wè moun
malad.

Doktè a bay Penyèl remèd pou malarya.

Woz, yon ti fi sansib

Woz se yon ti fi kout.
Li gen jansiv vyolèt.
Samdi apremidi,
pandan l ap mete
rad sou li pou al jwe
ak zanmi li yo, li wè
manman l k ap souffri.



Li di : « Manman
sa ou genyen ? » Manman li reponn : « Mwen gen
vant fè mal. Maten an mwen sòti san manje. Gaz
anpare m. » San pèdi tan, Woz deside fè manje
pou manman l. Li al chèche lyann panye nan lakou
a. Apre sa, li koupe pen an ti moso pa ti moso. Li
rache pwawo. Jou sa a, li prepare yon bon soup pou
manman li. Woz kontan wè jan manman li bwè soup
la ak apeti. Manman an di li : « Mèsi pitit mwen.
Mwen fyè de ou. »

Kesyon

1. Ki sa ki te fè manman Woz ap souffri ?
2. Ki sa Woz te fè pou li ede manman li ?
3. Ki sa manman Woz di li lè li fin bwè soup la ?

Leson 139

M ap fè efò pou kè mwen toujou kontan.



aransò

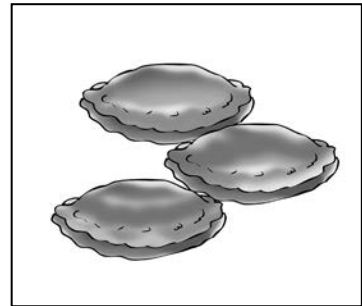

pate



Mwen viv nan lanmè ak nan rivyè

Pèchè yo kenbe mwen nan filè

Nan nas oswa ak zen.

Yo manje mwen tout jan,

Bouyi, fri oswa boukannen.

Mwen se _____.



marabou move tomat machann

bat farin zonyon lavant pate

aransò



Machann nan ap bat farin pou li fè pate.

Jilyo ap fri yon gwo aransò.

Leson 140

M ap prepare mwen anvan mwen patisipe nan yon konkou.

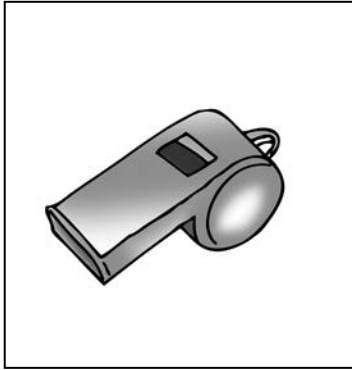

souflèt

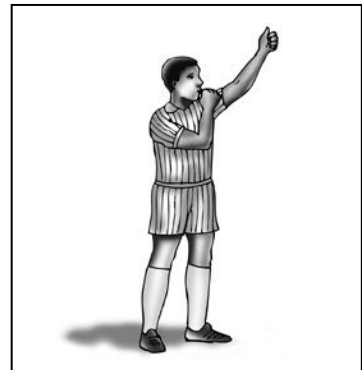

abit



Mwen se yon bèt

Mwen ka gen koulè gri, blan, nwa.

Mwen gen zòrèy long

Mwen gen moustach tankou chat

Yo gade mwen nan kalòj

Mwen renmen manje bwa patat ak kawòt.

Mwen se _____.



rapid siyal netwaye solid chòt

mayo kouri kanpe liy vitès



Sonya kouri rapid san li pa bouke.

Jozèl tann rad sou liy nan.

Yon bèl kous



Kalo ap viv nan katye Ganize. Li pa gen gwo kò. Men janm li yo solid. Sa pèmèt li kouri rapid. Yè te gen yon kous kouri nan katye a. Nan maten, Kalo leve byen bonè, li lave chòt ak mayo li, li netwaye tenis li. Nan pita, l al nan kous la. Li kanpe sou liy nan. Lè yo bay siyal, li tonbe kouri. Lè li vire gade deyè, li wè yon ti fi k ap kouri ak tout vitès. Woy ! Kalo ap pèdi kous la. Kalo kouri pi vit toujou. Weeee ! Kalo genyen kous la. Li kontan.

Kesyon

1. Ki sa Kalo te fè anvan li ale nan kous la ?
2. Ki sa Kalo fè lè li rive nan kous la ?
3. Ki sa Kalo fè lè ti fi a ap vini ak tout vitès deyè li ?

Leson 141 Revizyon

M ap aprann sere pou demen.



Chak jou se yon jou.

Jodi pa demen.

Mwen p ap gaspiye sa mwen genyen

Pou m ka viv demen ak kè kontan.



lokalite wouj repo cheni

manke rale kèk jòn vèt

moman



Makson ap viv depi kèk tan nan lokalite
Grasèt.

Cheni an tounen yon papiyon nwa.

Leson 142 Revizyon

M ap manje manje peyi mwen ak kè kontan.



Lakay se lakay

Mwen p ap jete pwodui lakay.

Pwodui lakay se pwodui natirèl.

Yo santi bon, yo bon nan bouch.

Wouloulouy ! Pwodui natirèl se sa nèt.



vach lèt boutèy solèy bòl

zèb deside toudabò mete kaye



Popo renmen bwè lèt.

Manno depoze boutèy la sou tab la.

Leson 143 Revizyon

Polisye yo rann nou anpil sèvis, nou dwe respekte yo.



Yon polisye nan yon zòn
La pou li sèvi ak pwoteje
Li ede epi bay sekirite
Nan tout vil, nan tout katye
Yon polisye se yon nesesite.



sikilasyon granmoun polisye
ankouraje sitwayen kò jèn elèv
souflèt pwoteje



Polisye a ankouraje jèn yo pwoteje
granmoun yo.
Yon bon sitwayen kwè nan ede moun.

Yon polisye modèl



Sara se yon jèn polisye gwo kò. Lè l ap fè sikilasyon nan lari a, li ede granmoun ak elèv lekòl travèse. Anvan lekòl lage, li kouri ale manje. Apre yon ti tan, Sara pran souflèt li pou li kontinye fè sikilasyon. Li toujou ankouraje chofè yo pou yo pridan. Lè swa li konn oblije rete travay byen ta. Sara kwè nan sèvi ak pwoteje sitwayen yo.

Leson 144 Revizyon

Chak fwa mwen fè erè, m ap rekòmanse
jiskaske mwen reyisi.



Mwen p ap dekouraje.

M ap kontinye fè plis efò

Jiskaske mwen rive.

M ap vanse, mwen p ap kanpe.

Pi lwen, mwen vle rive.



kajou fen fason konprann gwosè

fòs leve fawouche kontinye kase



Mariz toujou di timoun yo pa fawouche yon
moun pou gwosè li.

Gari konprann vit lè w ap pale avèk li.

Leson 145 Revizyon

M ap jwe pou mwen ka byen grandi.



Timoun, timoun, vini jwe.

M ap jwe.

W ap jwe.

Nou tout ap jwe.

Ansanm n ap byen grandi.

Oye oye, weeeeeeee !



marèl nimewo kawo moso konn
trase voye touse jwe pantalon



Yolèn konn jwe domino.

Maslen trase yon liy dwat sou tablo a.

Jwe marèl



Bazil ak Boni ap viv katye Laviwonn. Yon jou, de zanmi yo decide jwe marèl. Premyèman yo, trase kawo yo. Dezyèmman yo, mete nimewo nan kawo yo. Twazyèmman yo, pran yon ti moso twal, yo mouye l pou yo ka voye l nan kawo yo. Bazil di Boni :

- Mwen konn jwe marèl anpil.

Boni reponn li :

- Mwen pral wè kilès ki pi konn jwe.

Boni touse pye pantalon li. Finalman yo, kòmanse jwe.

Leson 146 Revizyon

M ap pran swen tèt mwen pou m evite
maladi.



Viv ansante se bèl bagay !

Viv an sante se sa mwen vle.

M ap lave men m avan mwen manje.

M ap mete rad ki pwòp.

Viv an sante se sa mwen vle.



marabou ankouraje egzamen lafyèv
konsilte medikaman mal fwi lave
tèt legim tifoïd



Mamay pran medikaman pou tèt fè mal.
Woni lave fwi yo anvan li manje yo.

Leson 147 Revizyon

Fi tankou gason ka gen menm metye.



Mwen se plonbye, se metye pa mwen
Ou se elektrisyen, se metye pa ou
Li se ebenis, se metye pa li
Yo se boulanje, se metye pa yo
Nou chak gen metye pa nou
Men fi tankou gason ka gen menm metye.



pantan elektrisyen rad konpayi
sezi kouran twò etidye travay
kè sousi



Manouchka pa renmen lè ti frè li a fè li
pantan.
Kou yo bay kouran an, Franswa pase rad li
yo.

Yon gwo elektrisyen



Mariz se yon jèn fi nan bouk Meridyen. Li pa twò kout ni twò gwo. Sousi li yo prèske kontre. Tout zanmi Mariz yo konnen li pè kouran anpil. Yon jou, pandan l ap pase rad li yo, li pran nan kouran. Li pantan, li sezi, kè l bat fò anpil. Depi lè sa a, Mariz decide ale etidye pou li vin elektrisyen. Mariz pa pè kouran ankò. Se konsa, Mariz vin ale travay nan konpayi ki vann kouran.

Leson 148 Revizyon

M ap toujou sonje zèv zansèt nou yo.



Mwen renmen listwa peyi m.
Zansèt nou yo te travay anpil.
Yo te konstwi anpil fò,
Pou pwoteje peyi nou.
Mwen respekte zansèt nou yo,
Paske yo te batay pou ba nou libète.



pwofesè patisipe klas aplodi
prepare pyès fèt bèl jèn
repetisyon



Elèv yo monte yon bèl pyès teyat.
Pwofesè Jini ede jèn yo prepare fèt la.

Leson 149

M ap respekte andikape yo.

Naratè : Evnò gen setan. Li rete katye Bèlvi. Li yon ti jan panche agoch lè l ap mache. Li menm ak Chèlin se bon zanmi. Lòt jou, pandan y ap soti lekòl ansanm, yo rankontre Katya. Katya tonbe annwiye Evnò.

Katya (*l ap chante*)

Evnò kokobe, we !

Evnò kokobe, we !

Evnò (*fache*)

Katya, mwen pa rele kokobe. Mwen rele Evnò.

Katya (ri byen fò)

Woy ! Ou pa rele kokobe?

Pye w tou kwochi. Ou pa menm ka mache dwat.

Chèlin (*vwa li poze*)

Katya, kite ti gason an anrepo non.

Katya (*pran pòz move l*)

Oo pèsòn pa ka anpeche m rele Evnò kokobe.

Evnò (*move kou kong*)

Mwen pral fè w sispann rele m kokobe.

Chèlin (*l ap pase lòd*)

Evnò, ou pa pral batay non.

Evnò (*move pi rèd*)

E byen, ki sa ou vle mwen fè pou Katya sispann
nui m ?

Chèlin (*Yon ti vwa dous*)

Evnò ou pa bezwen okipe l. Epitou, ou menm
Katya, ou dwe konnen yon andikape se yon moun
menm jan ak tout moun. Nou dwe respekte l.

Naratè : Katya, Evnò ak Chèlin kontinye ap pale
anpil. Se konsa Pè Riche vin ap pase. Pandan Pè
Riche ap soti nan jaden, li wè Katya, Chèlin ak
Evnò k ap pale

Leson 150

M ap respekte andikape yo

Naratè : Pè Riche ap pase. Lè li wè Katya, Chèlin ak Evnò ap pale fò, li kanpe pou l pale avèk yo.

Pè Riche (*sezi*)

Sa nou genyen ? Pou ki sa tout pale anpil sa yo ?

Evnò (*tankou yon moun k ap pote plent*)

Katya k ap annuiye m wi Pè Riche.

Li chita ap rele mwen kokobe.

Pè Riche (*ton otoritè*)

Katya, ou pa gen dwa rele Evnò kokobe. Ou konn bon non l.

Katya (*ton fawouchè*)

Men Pè Riche, li kokobe vre !

Pè Riche (*serye*)

Ou pa gen dwa fawouche yon moun ki andikape.

Ni tou, ou pa gen dwa fè blag ak sa.

Leson 150

Chèlin (*l ap fè bas*)

Mete pou li Pè Riche.

Chak tan Katya rele Evnò kokobe, li tonbe ri.

Se pa ti kontan li kontan non.

Pè Riche (*l ap konseye*)

Katya pitit mwen, ou pa gen dwa pran plezi nan andikap yon moun.

Okontrè ou sipoze ede moun nan.

Evnon (*li kal, li poze*)

Ede moun ! Katya pa nan bagay konsa. Pou Katya, se konsa mwen fèt. Men li pa konnen, lè mwen te tou piti mwen te fèt tifoïd. Yo pa t mennen m kay doktè atan. Se sa ki lakòz mwen gen yon janm ki defòme.

Katya (*sezi*)

Mwen panse se tou konsa ou te fèt wi!

Pè Riche

Gen moun ki fèt tou andikape. Konsa tou, gen maladi si ou pa pran bonè ak yo sa ka lakòz yon moun vin andikape.

Leson 150

Evnò (*l ap pale ap fyète*)

Se vre mwen andikape. Men, mwen se moun menm jan ak tout moun. Mwen vle pou yo respekte m. Epitou, mwen se bon jwè foubòl.

Chèlin (*li kontan*)

A papa ! Evnò konn bay bèl trib. Epitou, depi gen konkou chenè nan katye a, li toujou chanpyon.

Katya (*li pale tankou yon moun regrèt*)

Evnò, mwen p ap janm rele w kokobe ankò. Mwen vle zanmi w. Epitou, depi jodi a, m ap rele w Evnò.

Pè Riche (*kontan*)

Bravo, nou dwe respekte ak apresye tout moun.



Liv sa a fèt epi li pibliye an kolaborasyon avèk Ministè Edikasyon Nasyonal ak Fòmasyon Pwofesyonèl (MENFP) Gouvènman Ayisyen a, gras a yon èd ki soti nan ajans ameriken U.S. Agency for International Development (USAID), nan kad Aktivite Rechèch Aplike Tout Timoun Ap Li – ToTAL, dapre kontra No. EHC-E-00-0004-00 pwogram èd USAID ki rele EdData II Technical and Managerial Assistance.

Jiyè 2014